

## Seminar M-16:

# New Developments in Touch Technologies



**Geoff Walker**  
**Principal Analyst**  
**IMS Research**



# M16: New Developments In Touch Technologies

**Part 1:** What's Happening On  
the Leading Edge of Touch

---

**Part 2:** Touch Technologies for eReaders

**Geoff Walker**  
**Principal Analyst**  
**IMS Research**

May 16, 2011

**File Download:** [www.walkermobile.com/SID\\_2011\\_Seminar\\_M16.pdf](http://www.walkermobile.com/SID_2011_Seminar_M16.pdf)

# Part 1:

## What's Happening on the Leading Edge of Touch



# Agenda – Part 1

---

- ❖ Introduction [4]
- ① Projected Capacitive [6]
- ② Vision-Based [4]
- ③ Camera-Based Optical [3]
- ④ In-Cell, On-Cell & Out-Cell [4]
- ⑤ Infrared [3]
- ⑥ Analog & Digital Multi-Touch Resistive [4]
- ⑦ Surface Acoustic Wave (SAW) [3]

[Total = 31]

# About IMS Research

## ❖ IMS Research

- ◆ A leading independent supplier of market research and consulting to the global electronics industry

Automotive & Transport	Financial & ID Technologies
Communications & Wireless	Lighting & LEDs
Computer & Office Equipment	Medical (InMedica)
Consumer Electronics	Power & Energy
Convergence	Security & Fire
Displays & Touch	Semiconductor
Factory Automation	

- ◆ Offices in UK (HQ), USA, China, Taiwan, Korea & Japan
- ◆ >100 analysts worldwide
- ◆ Clients in >50 countries
- ◆ Publishes >200 market-research reports per year
- ◆ Known for detailed, in-depth, highly analytical reports

# Key Customers

SIEMENS

PHILIPS

Honeywell

HITACHI  
Inspire the Next



AMD  
Smarter Choice



MITSUBISHI  
ELECTRIC  
Changes for the Better



BOSCH

National  
Semiconductor

TEXAS  
INSTRUMENTS

Rockwell  
Automation

- ❖ 9 of the top 10 semiconductor companies

Seagate



- ❖ 8 of the top 10 automotive-electronics suppliers

CISCO

tyco

- ❖ 8 of the top 10 telecomm-equipment providers

- ❖ 7 of the top 10 power-supply companies

BLAUPUNKT

NXP  
founded by Philips

- ❖ All of the top 10 industrial-automation companies

- ❖ 7 of the top 10 set-top-box manufacturers



SAMSUNG

- ❖ All of the top 10 video-surveillance companies

THE NEW VALUE FRONTIER

KYOCERA

Panasonic  
ideas for life

ANALOG  
DEVICES

DANAHER

Infineon  
technologies

IBM

ZORAN

# A Simple Touch Isn't Simple...1

## ❖ Touch classification from the University of Toronto

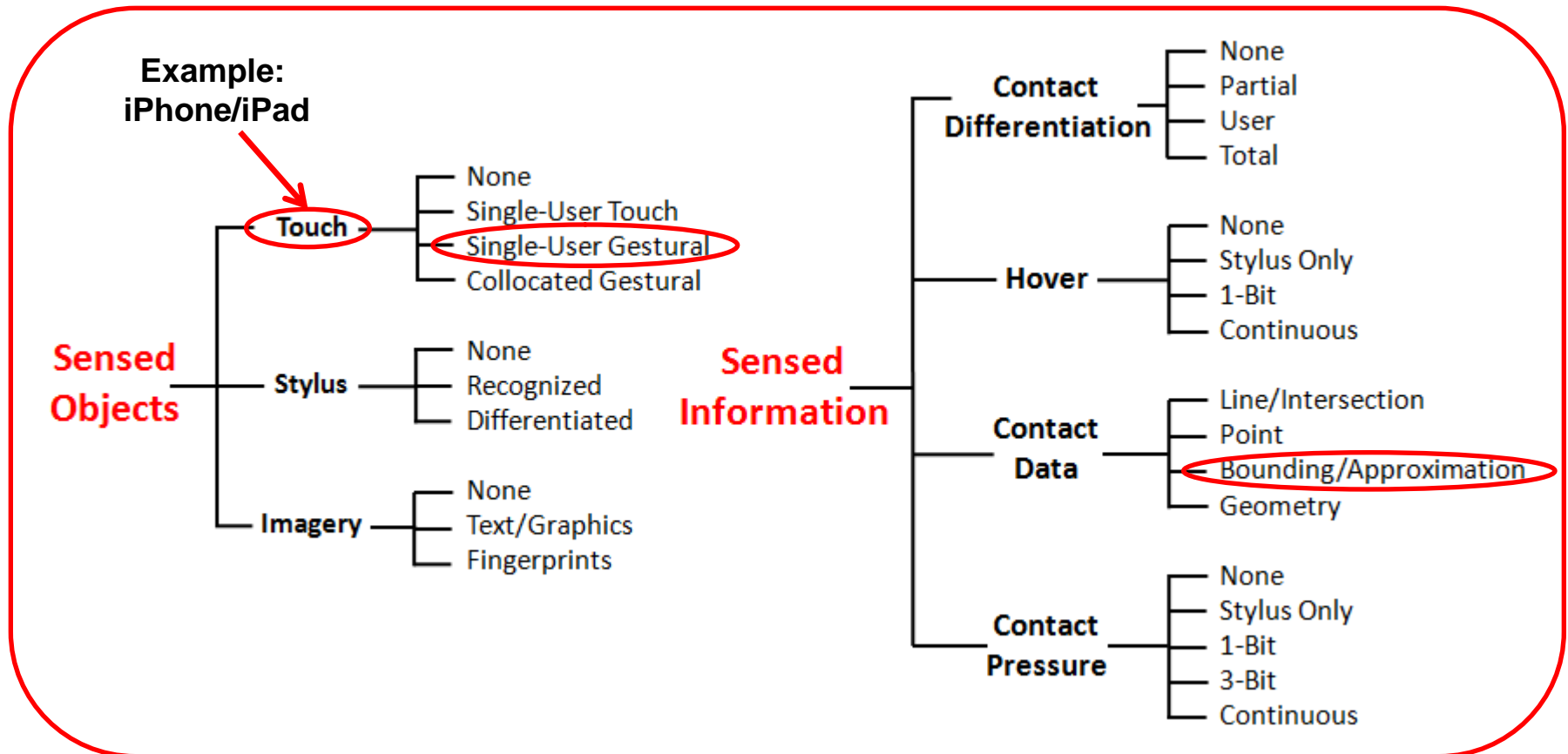

Source: Daniel Wigdor

# A Simple Touch Isn't Simple...2

- ❖ It's far more complex than just "how many touches?"

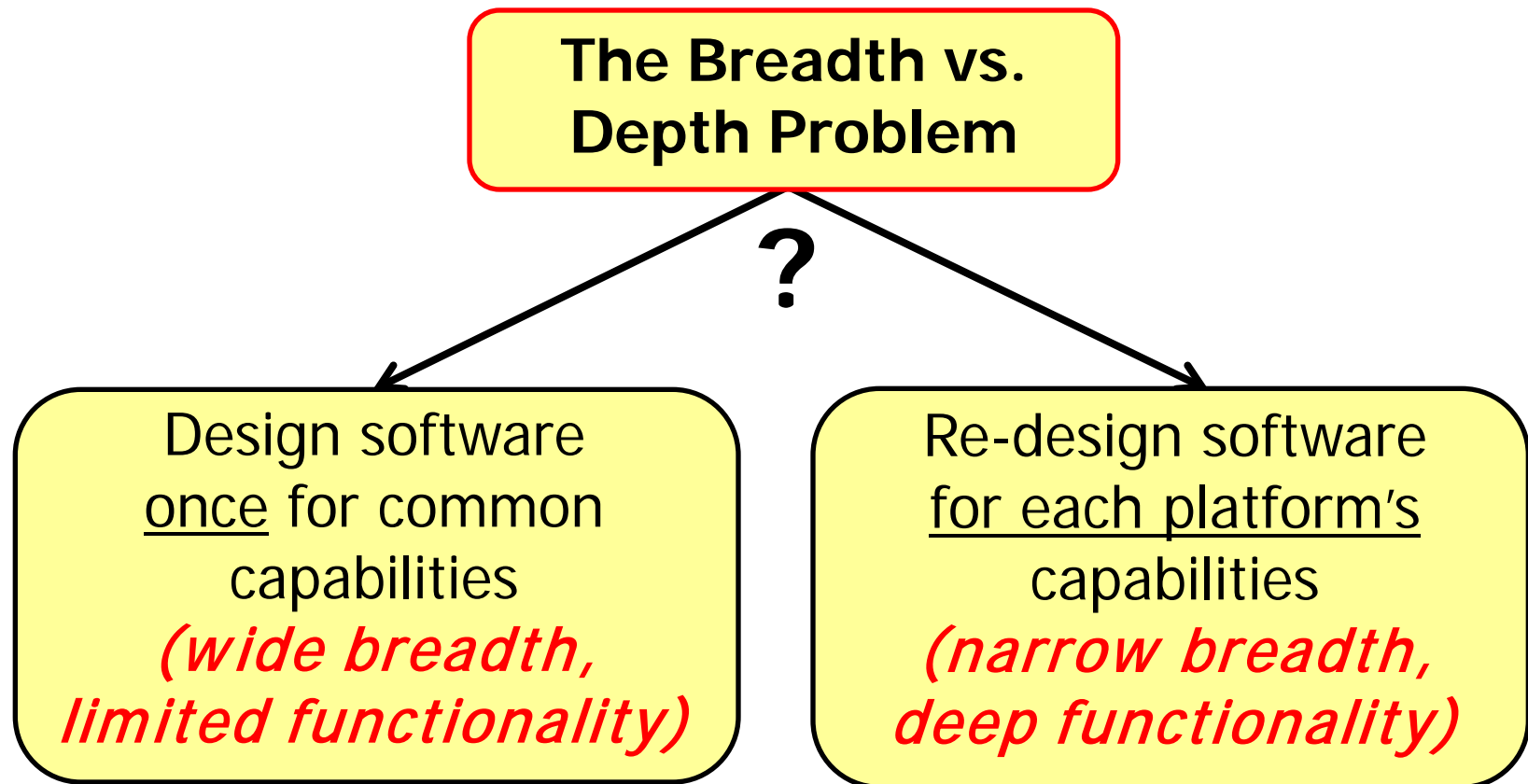

# Projected Capacitive...1

1

## ❖ Projected capacitive has become mainstream

- ◆ In 2006 (pre-iPhone), total worldwide sales of pro-cap were approximately **\$20M**
- ◆ According to DisplaySearch, pro-cap is estimated to be **\$3.1B** in 2010 (CAGR = 250%)
  - According to DigiTimes, the largest single supplier in 2010 (TPK Touch Solutions) was over \$2B

## ❖ Mobile phones & tablets are driving the market

- ◆ **50%** of the \$3.1B in 2010 was mobile phones (DisplaySearch)
- ◆ **30%** was Mini-Note PC/Tablet
- ◆ 14% was MP3(music) / PMP(media) / PND (navigation)

# Projected Capacitive...2

1

## ❖ Capacity is expanding extremely rapidly

- ◆ TPK, Wintek, CMI, Cando, Sintek, Young Fast, AUO, CPT, etc. are all adding glass-type pro-cap capacity (mostly 2.5G – 5.3G)

## ❖ Construction is stabilizing

- ◆ Film-type and glass-type (~50/50) for mobile phones
- ◆ Glass-type for larger products (e.g., iPad)
  - **“One-glass”** (touch on underside of cover lens) is the current industry direction

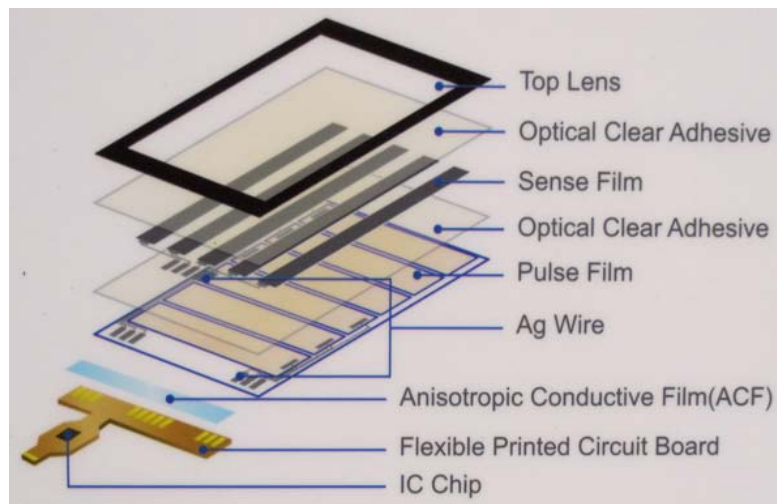

Source: Sony Chemical

# Projected Capacitive...3

1

## ❖ Usable stylus is almost here

- ◆ Atmel, Cypress, Maxim (controller-IC suppliers) are all saying they can support a conductive stylus with **1-mm tip**
- ◆ Higher signal-to-noise-ratio (SNR) controllers are enabling this

### Capacitance Profiles

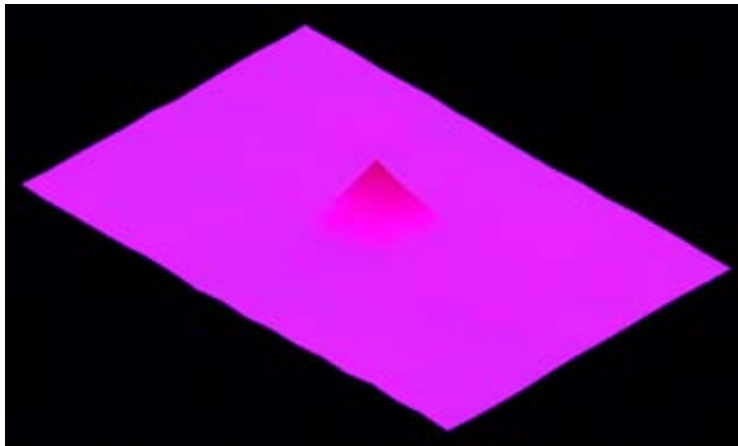

2-mm stylus on 4" screen  
with high-SNR controller

Source: Maxim

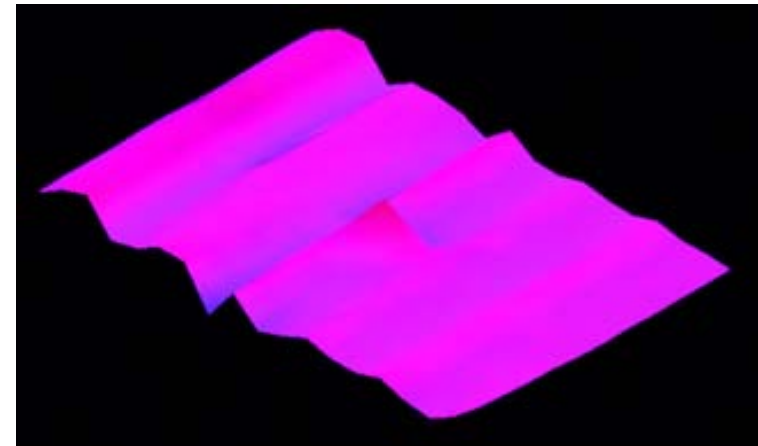

Same stylus and screen  
with low-SNR controller

# Projected Capacitive...4

1

## ❖ Hitachi's claimed "non-conductive pro-cap stylus"

- ◆ Shown at FPD International in Japan (November 2010)
- ◆ Probably is a combination of pro-cap and voltage-sensing in-cell (pressure-sensitive) touch, **NOT** just pro-cap



Source: Photo by author

# Projected Capacitive...5

1

## ❖ The maximum size has expanded to 32"

- ◆ 3M & TPK/MasTouch have 32" pro-cap monitors
- ◆ Asus has a 27" pro-cap all-in-one touch computer (ET2700)



Asus  
10-touch  
27" AiO

Source: [TheTechJournal.com](http://TheTechJournal.com)



3M 10-touch  
32" monitor

Source: 3M

- ◆ High-volume cost is \$3/inch

# Projected Capacitive...6

1

## ❖ Performance is increasing

- ◆ **Consumers don't want to wait for the touch system!**
- ◆ 3M is the current champion with 40+ touches on 22" pro-cap monitor at 200 samples/second/touch (5 ms)

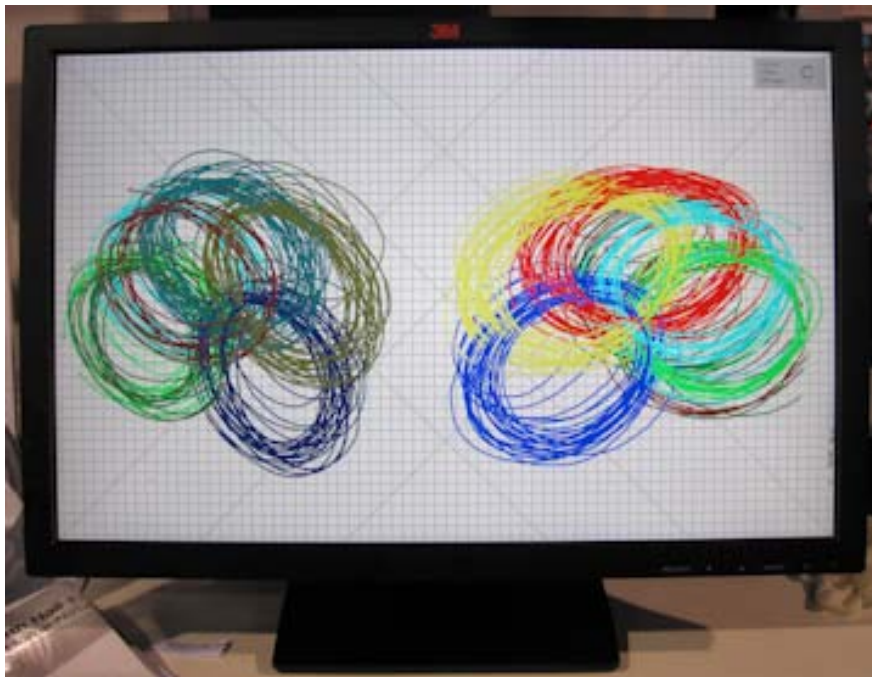

3M 22" pro-cap monitor  
with 10 fingers moving  
as fast as possible

Source: Photo by author

# Vision-Based...1

2

## ❖ Microsoft/Samsung announced **Surface v2** at CES 2011



Source: TechCrunch.com

Document on surface



Source: Microsoft

## ❖ What is Surface v2?

- ◆ **“Connects people to information and each other” (Microsoft)**
- ◆ 40” full-HD (1920x1080) Samsung LCD (55 ppi)
  - 4” thickness includes 2.9 GHz PC with embedded 64-bit Win-7
- ◆ Corning Gorilla Glass bonded to LCD
  - Display still has some bezel height (not a flush surface)
- ◆ **In-cell touch:** 1 light-sensor per pixel = 2M sensors
  - By far the most sophisticated in-cell light-sensing so far
  - Half of sensors are IR; other half are visible-light (best of both)
  - RGB pixels may be modified to reduce effect on aperture ratio
  - IR light source is probably added to backlight (uncertain)
- ◆ 50+ simultaneous touch points
  - Surface image-processing software is Microsoft’s primary value-add
- ◆ \$7,600 – targeted at enterprise

# Vision-Based...3

2

❖ The number of “touch tables” is rapidly increasing



## ❖ Why does vision-based touch matter?

- ◆ It's the only touch technology that can do true **object-recognition**  
*which...*
- ◆ Enables integrating the **physical world** and the **virtual (digital) world** more closely  
*which...*
- ◆ Makes **digital information** more easily accessible when users interact with a **physical object**

***Which has more potential to change the world,  
projected capacitive or vision-based touch?***

## ❖ Camera-based optical is starting to mature

### ◆ Windows 7 on all-in-one (AiO) desktops is #1 volume

- Optical hits the sweet spot of price and performance compared with other touch technologies for all-in-ones
- Almost all desktop PC OEMs & ODMs are using optical



## ❖ Large-format (> 30") camera-based optical is growing

### ◆ Key applications

- Interactive information
- Interactive digital signage
- Education (including opaque & LCD interactive whiteboards)

- ❖ Two touches with two cameras (current market focus) has two main limitations

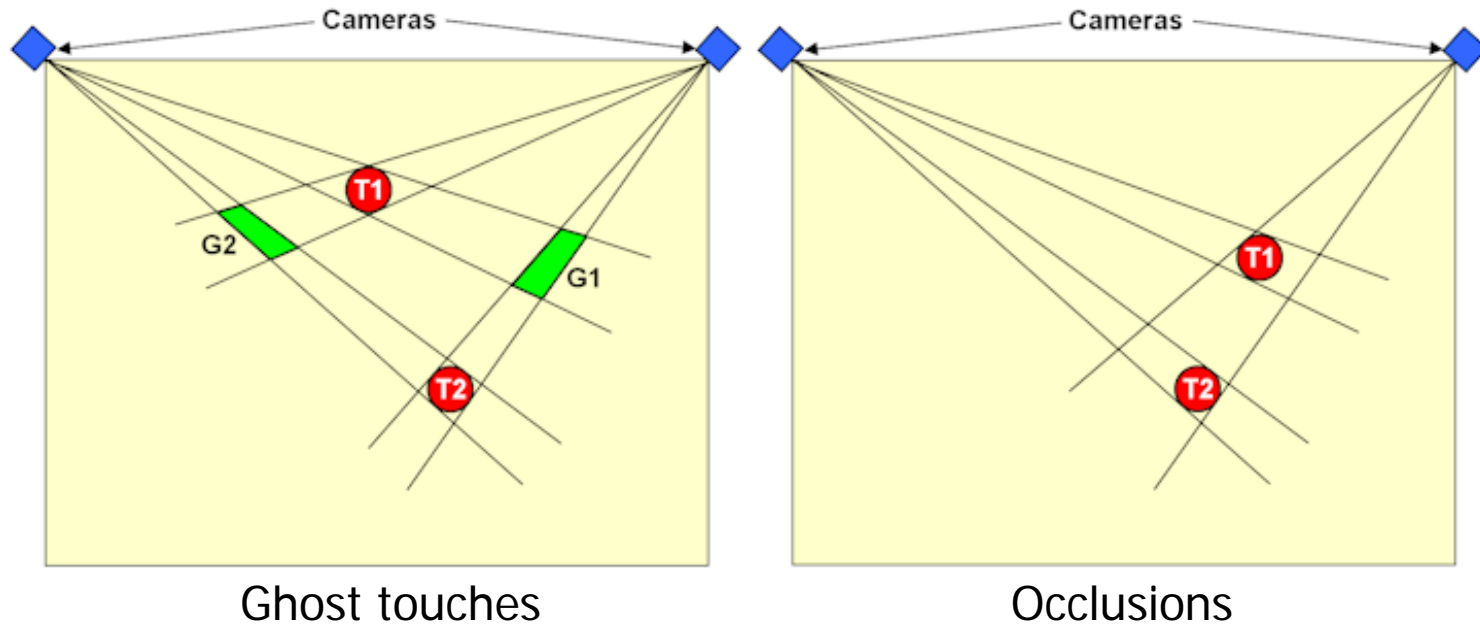

*The quality of the touch experience depends on the sophistication of the algorithms that handle ghost touches and occlusions*

## ❖ Products with 3 cameras

- ◆ Adding a third camera doesn't actually improve the touch quality very much because there are still ghost touches and occlusions
- ◆ Using four cameras eliminates essentially all of these problems, but most PC OEMs perceive that two-camera performance is "good enough" and aren't willing to pay for four cameras



Dell ST2220T  
Touch Monitor  
with 3 cameras

## ❖ Definitions

- ◆ **In-cell:** Touch sensor is inside the LCD cell, between the two sheets of glass
- ◆ **On-cell:** Touch sensor is on top of the color filter glass, underneath the polarizer
- ◆ **Out-cell:** Touch sensor is on top of the LCD (normal)

## ❖ Technologies

Touch Technology	Location	Status
Light-sensing	In-cell	Difficult technical problems; see Surface v2
Voltage-sensing	In-cell	Used only in hybrid combinations
Charge-sensing (capacitive)	In-cell & on-cell	Limited success in-cell; strong success on-cell (products in the pipeline)
Hybrid voltage-sensing & charge-sensing	In-cell	A few products on the market (e.g., digital cameras)
All other technologies	Out-cell	Business as usual

# In-Cell, On-Cell & Out-Cell...2

4



First product with in-cell (hybrid) touch (April 2009)



First product with optical in-cell touch (May 2009)



2<sup>nd</sup>-gen camera with hybrid in-cell touch (August 2009)



First OLED product with on-cell touch (Feb 2010)



Largest (13.3") on-cell finger-touch (charge-sensing) product so far (Feb 2010)

# In-Cell, On-Cell & Out-Cell...3

4

## ❖ Special case: Integrated Digital Technologies, Inc.



Source: IDTI



Source: Photo by author

- ◆ 21.5" light-sensing in-cell monitor with **IR light-pen**
- ◆ Supports two-touch with two pens

## ❖ Out-Cell Projected Capacitive

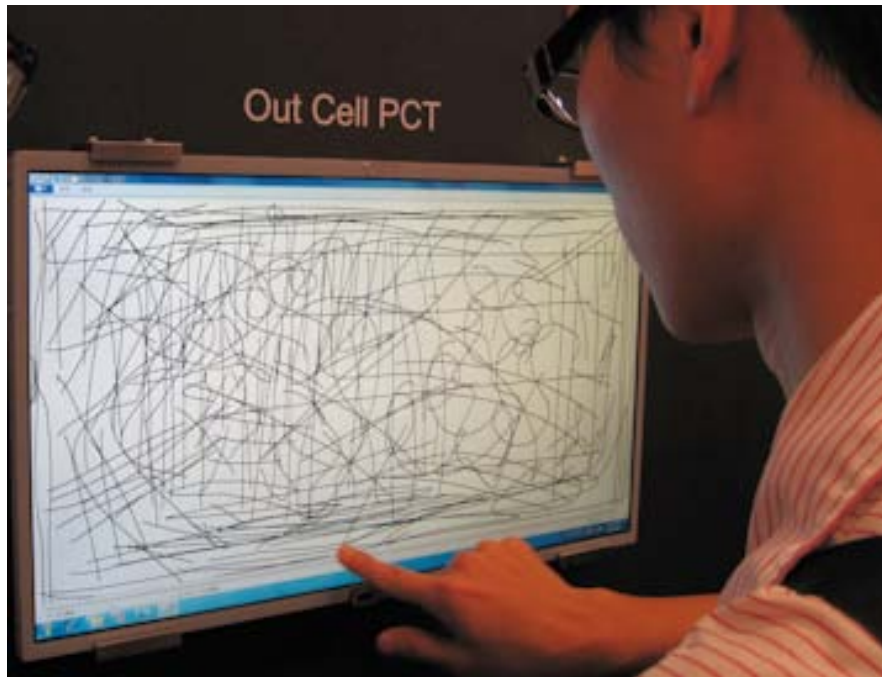

CPT 21.5"  
2 touches



AUO 32"  
10 touches

Source: Photos by author

## ❖ Multi-touch in traditional infrared

- ◆ 2+ touches
- ◆ Suppliers: IRTouch, Groovy Touch, Leading Touch, etc.
- ◆ “Ghost” points are the problem, and **there’s no good solution**

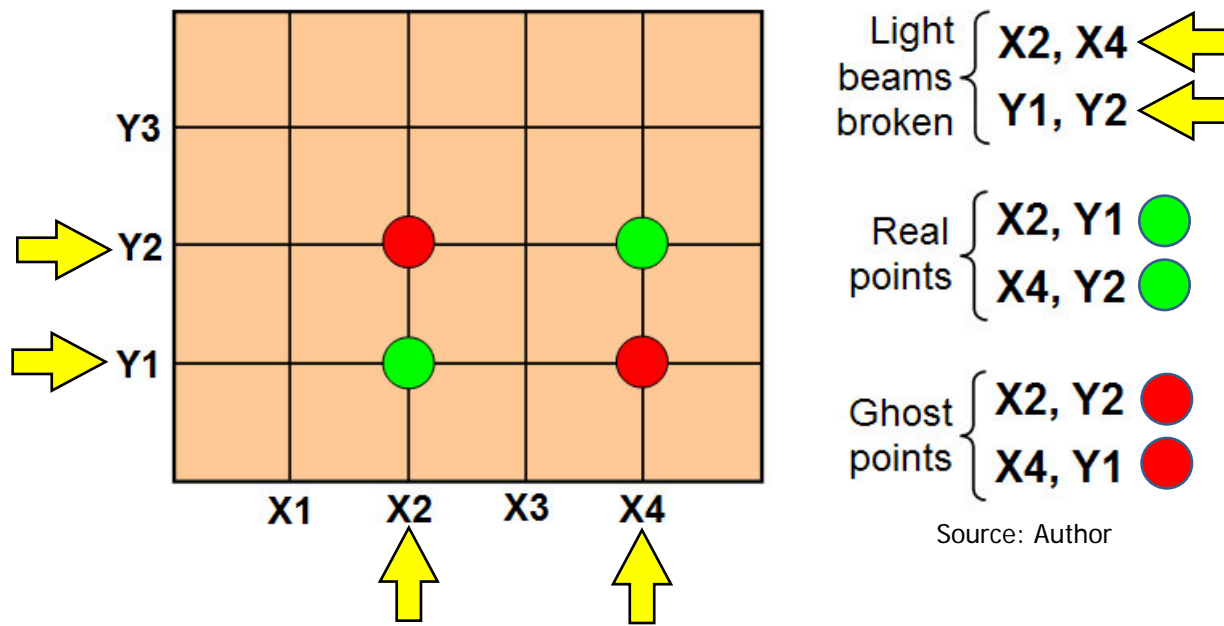

## ❖ Multi-touch in “LED Cell Imaging” infrared

- ◆ 20-30 touches
- ◆ Suppliers: PQ Labs, Citron



Source: PQ Labs

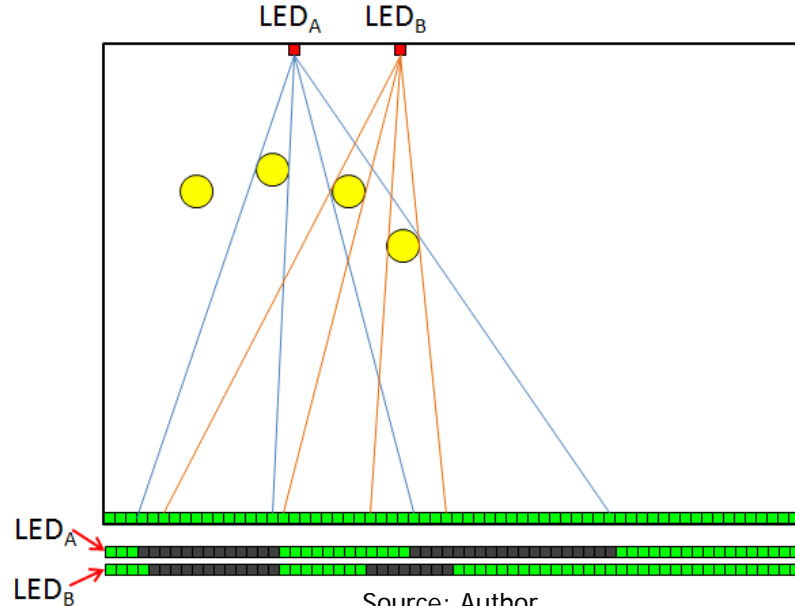

- ◆ Issues: Relatively low resolution and slow response time

## ❖ Infrared in mobile devices



Neonode  
cellphone  
(2009)

Source: Pen Computing



RPO **waveguide infrared**  
in prototype 13.3" notebook  
from LG Displays (2010)

Source: Photos by author



Sony e-book  
readers (2010)

Source: PC World

RPO in  
Mirasol  
screen  
(2010)



# Analog & Digital Multi-Touch Resistive (AMR & DMR)...1

---

6

- ❖ **Both are alternatives to projected capacitive**
  - ◆ Familiar resistive technology
  - ◆ Patterned ITO (like pro-cap) instead of single-touch resistive's continuous ITO
  - ◆ Lower cost
- ❖ **But, both have standard resistive shortcomings**
  - ◆ Low durability (PET top surface)
  - ◆ Low transmissivity
  - ◆ Non-zero touch force

# Analog & Digital Multi-Touch Resistive (AMR & DMR)...2

6

## ❖ AMR (also called “hybrid analog-digital”)

- ◆ Suppliers: eTurboTouch, Mildex, Mutto, EETI, ATouch...
- ◆ Limited IP on concept
- ◆ Number of touch points is controller-dependent (2-10)
- ◆ Offered in 3” – 23”, but not actually in production in all sizes
- ◆ **Can't touch with two fingers on the same square**

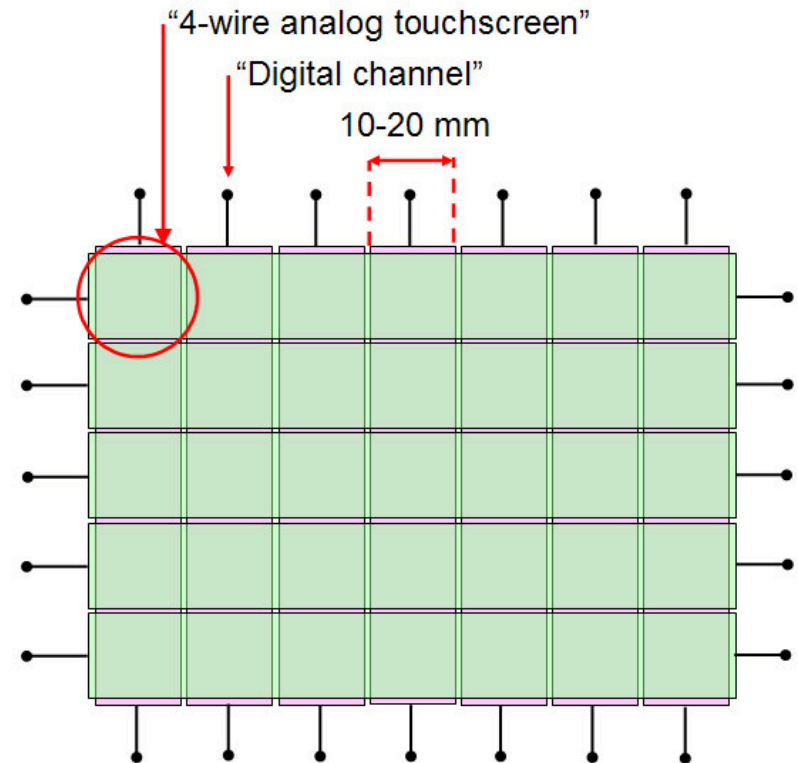

Source: Author

# Analog & Digital Multi-Touch Resistive (AMR & DMR)...3

6

Gateway ZX6910 AiO with 23" **AMR** touchscreen from eTurboTouch



Source: Photos by author

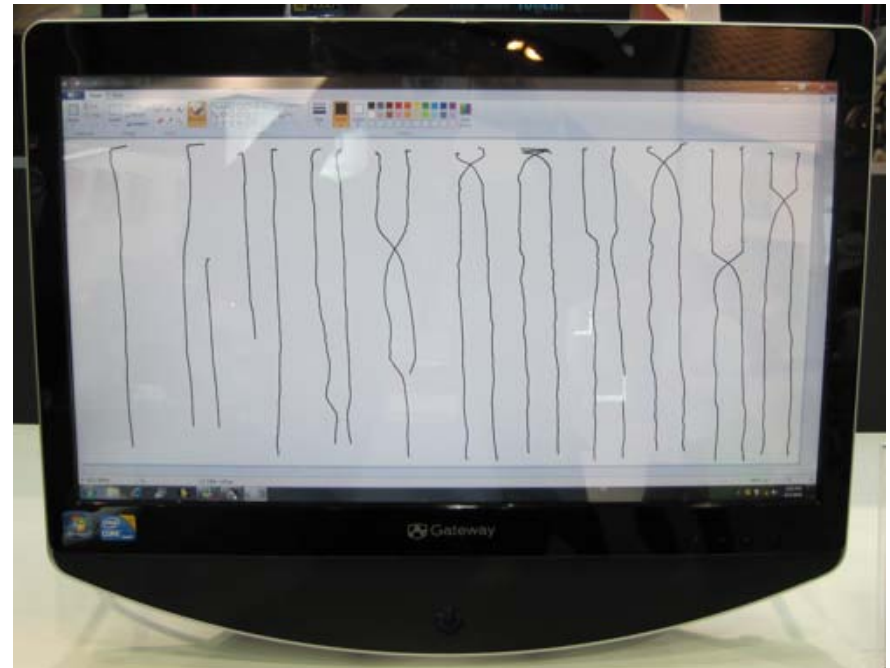

Drawing parallel lines with two closely held fingers (squares are 13 x 15 mm)

*"There is no perfect touch technology"*

# Analog & Digital Multi-Touch Resistive (AMR & DMR)...4

6

## ❖ DMR (also called “digital matrix resistive”)

- ◆ Stantum (in France) is primary IP holder
- ◆ Stantum’s strategy is to license controller IP to IC manufacturers
  - Sitronix
  - ST Micro
- ◆ Unlimited number of touch points
- ◆ Aimed at phones and netbooks
- ◆ **Fine pitch results in much higher number of connections than AMR**
  - $64 \times 36 = 100$  on 4.3” screen

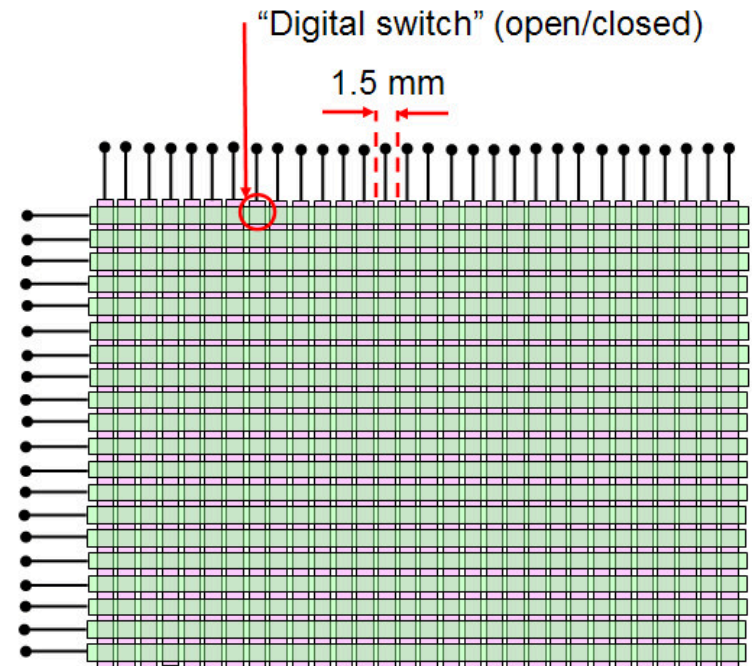

Source: Author

Intel-Quanta  
“Redvale”  
Tablet

Source: Stantum

# Surface Acoustic Wave (SAW)...1

7

## ❖ How two touches are supported by SAW

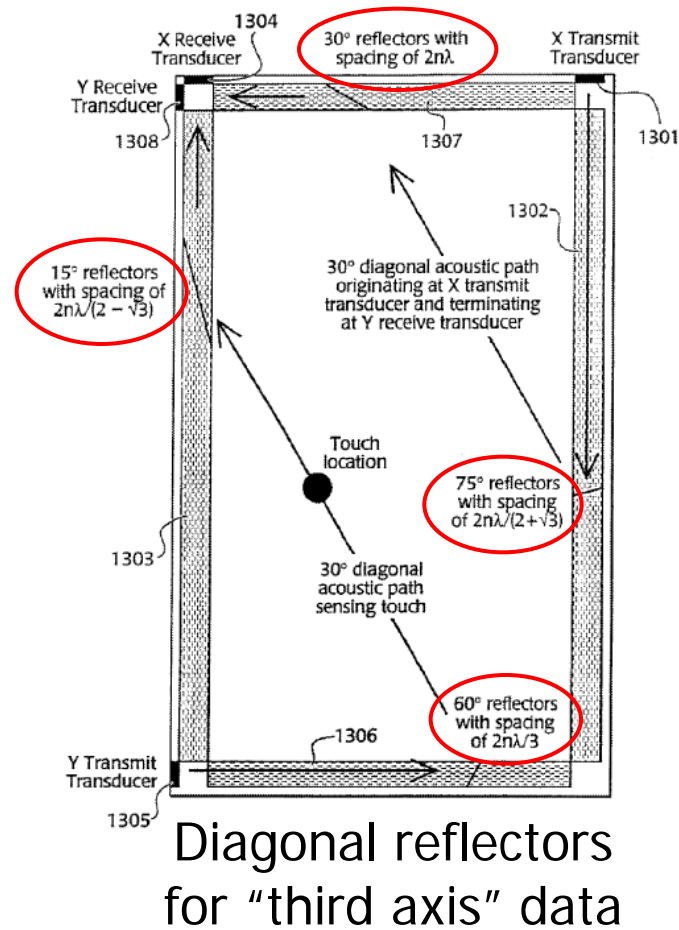
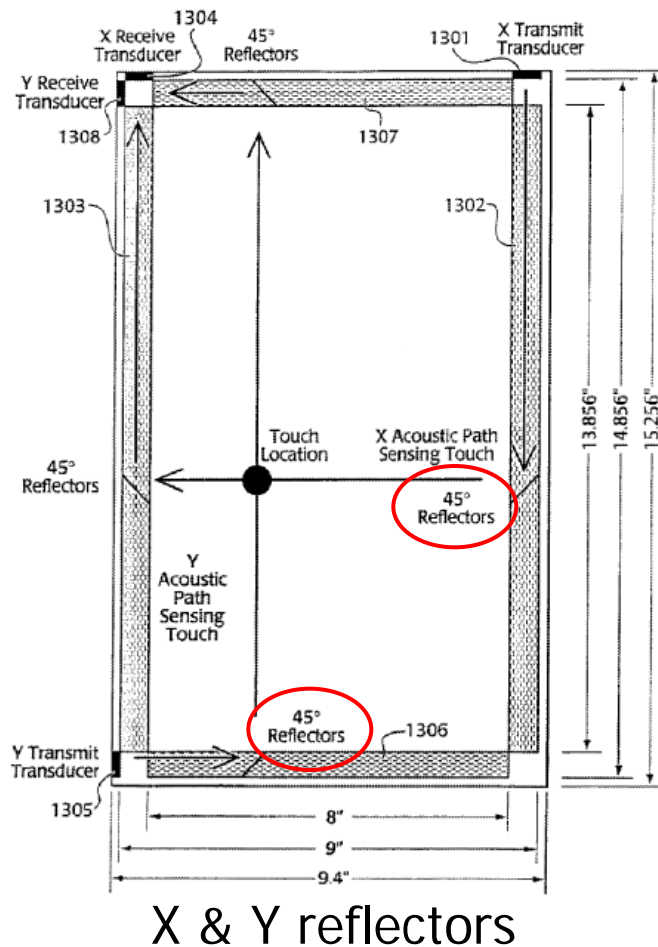

# Surface Acoustic Wave (SAW)...2

7

## ❖ Multi-touch SAW from Elo/Tyco Electronics

- ◆ Shipping in the 23" Lenovo A700 all-in-one desktop



Source: Lenovo

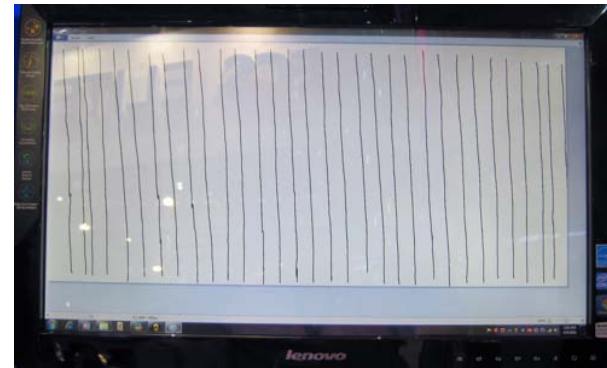

2-finger vertical lines



2-finger diagonal lines

Source: Photos by author

*"There is no perfect touch technology"*

# Surface Acoustic Wave (SAW)...3

7

## ❖ Elo/Tyco Electronics' "zero-bezel" (flush) SAW

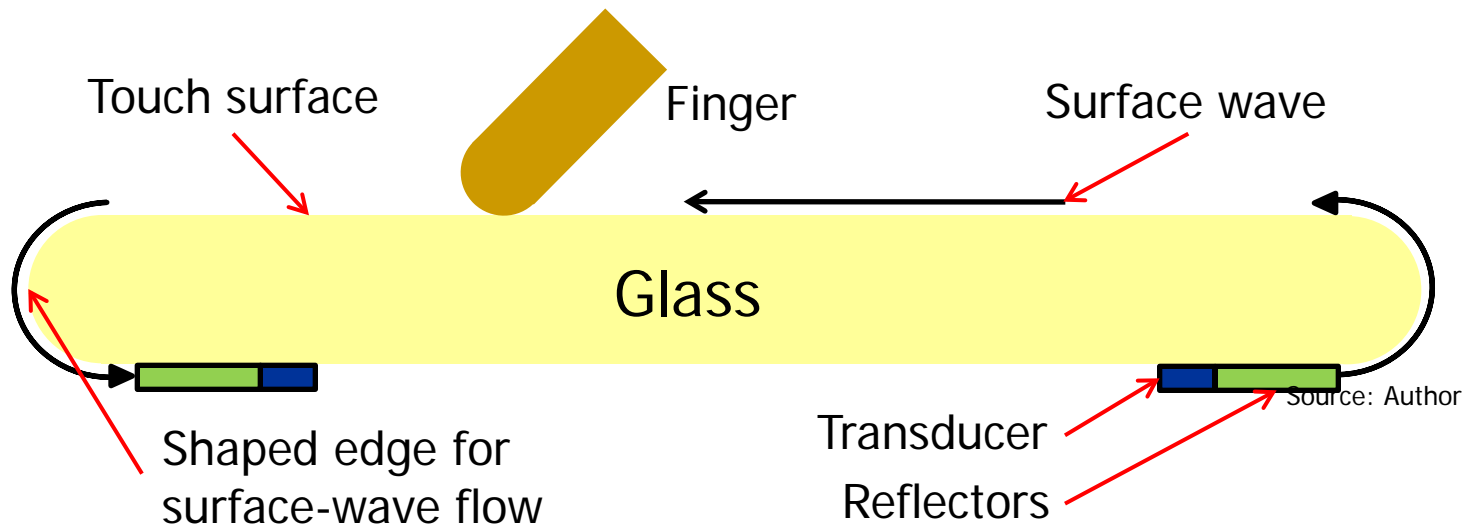

# Conclusions – Part 1

---

- 1: ***“Change is the only constant”  
(especially in touch!)***
- 2: ***“There is no perfect touch  
technology”***

# Part 2:

# Touch Technologies for eReaders



# Agenda – Part 2

---

- ❖ **Touch-Usage Requirements [1]**
- ❖ **System-Level Requirements [1]**
- ❖ **Current Touch Technologies [4]**
  - ◆ Electromagnetic resonance pen digitizer (EMR), capacitive, traditional infrared, and resistive
- ❖ **Emerging Touch Technologies [2]**
  - ◆ Waveguide infrared [RPO]
  - ◆ EMR with integrated force-sensing [Hanvon]
- ❖ **Potential Touch Technologies [3]**
  - ◆ Traditional force-sensing, Acoustic Pulse Recognition/ReverSys [Elo], and embedded (“in-cell/on-cell”)
- ❖ **Conclusions [1]**

[Total = 12]



# Touch-Usage Requirements

## ❖ Selection

- ◆ High accuracy

## ❖ Swipes

- ◆ Very light touch & fast response (iPhone set the standard)

## ❖ Zoom

- ◆ Multi-touch

- *Better with images stored at higher resolution than displayed*

## ❖ Annotation

- ◆ Stylus with palm rejection

- *Better with software infrastructure for saving annotations with location in text, even when text is reflowed*

- ◆ High-resolution ink for readability

- ◆ Desirable: Handwriting recognition (conversion from ink to text)



# System-Level Requirements

---

## ❖ Zero light loss (eReader = EPD!)

- ◆ Transmissivity: Light goes through the touch-screen twice!
- ◆ Reflectivity: Reflected light reduces image contrast

## ❖ Very low power consumption

- ◆ Typical usage model doesn't help
- ◆ Wake-up time is a compromise

## ❖ Durable & light weight

- ◆ Very Desirable: No added glass
- ◆ Hard surface for annotations

## ❖ Insensitive to ambient light

- ◆ Works in bright sunlight with lots of IR



# Current Touch Technologies...1

## ❖ Electromagnetic resonance pen digitizer (EMR)

- ◆ Most common “touch” technology in eReaders
  - Wacom & Hanvon are primary suppliers
- ◆ Sensor goes behind EPD, so no light loss
  - But NO finger touch, and electronic pen is at risk for being lost
- ◆ High resolution ink & inherent palm rejection
- ◆ Lack of infrastructure reduces value of annotation today

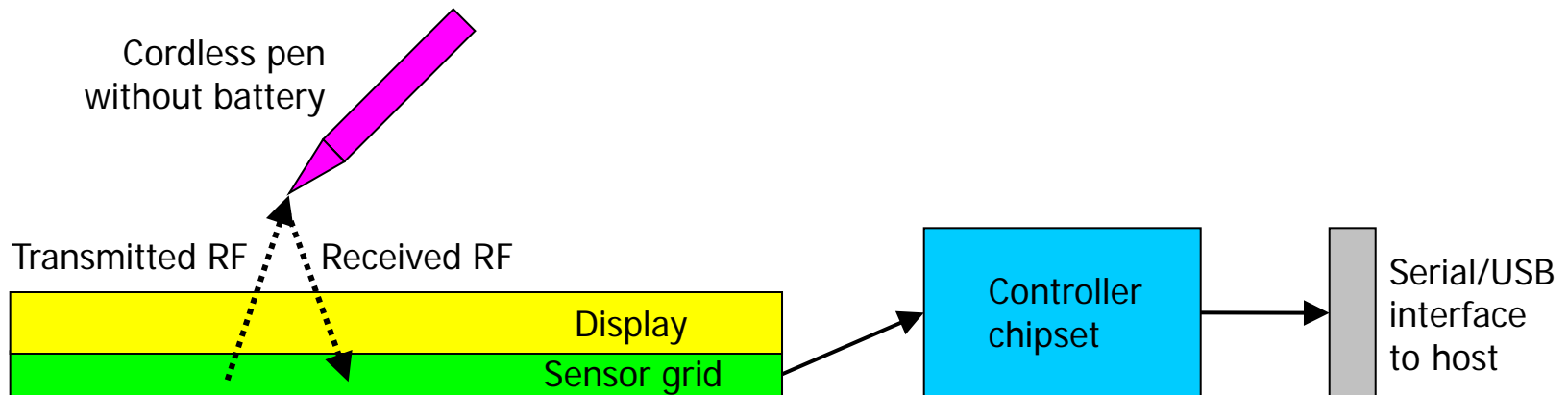

Source: Author

# Current Touch Technologies...2

## ❖ Capacitive

- ◆ Same technology as in iPhone & 100% of tablets
- ◆ Light touch & multi-touch
- ◆ Surface can be flush (“zero-bezel”)
- ◆ Light loss can be minimized to 2-4%
- ◆ Finger-only (so far), so no annotation
  - Palm rejection is achievable when stylus arrives
- ◆ Still very expensive: 7” ≈ \$25 OEM cost with controller (film/film/cover-glass)
- ◆ AUO/SiPix may be using film/film/no-glass or even “on-cell” (sensor deposited directly on top of EPD) with a hard-coat cover film

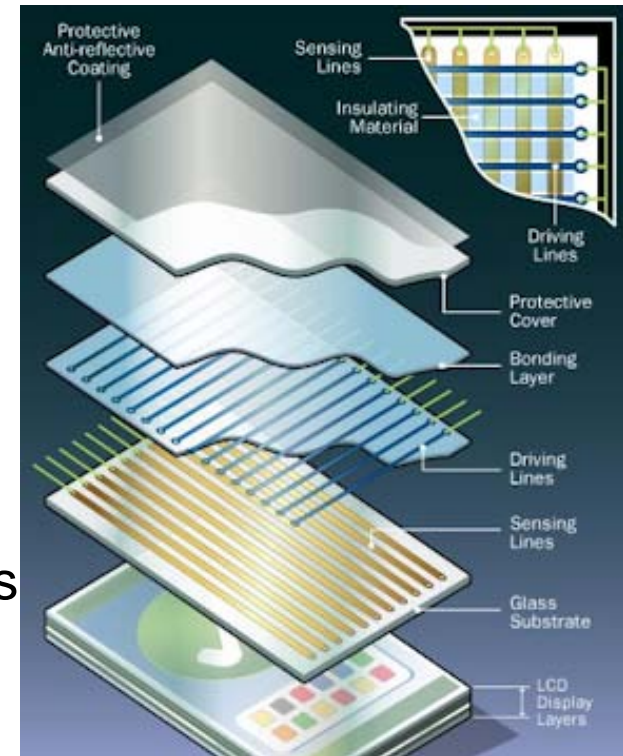

Source: HowStuffWorks.com

# Current Touch Technologies...3

## ❖ Traditional infrared (for mobile)

- ◆ Only one supplier today: Neonode (Sweden)
  - Small company licensing IP, not selling hardware
- ◆ Used in Sony, Koobe, and maybe others
- ◆ No glass, so no light loss
  - IR beams above EPD surface → non-flush bezel
- ◆ Relatively low resolution
- ◆ Doesn't scale very well



Source: Neonode and Pen Computing Magazine



# Current Touch Technologies...4

## ❖ Resistive on top of EPD

- ◆ All single-touch today
  - Nobody has announced the use of multi-touch resistive yet; it seems unlikely because it's not enough of an improvement
- ◆ Least desirable current technology
  - 15% to 20% light loss (glass + 2xITO + PET + air-gap)
  - Reducing surface reflectivity is expensive
  - Requires heavier touch
  - No palm rejection



Source: Sony

## ❖ Resistive *underneath* EPD

- ◆ Demonstrated by E-ink at SID 2010
- ◆ Potential solution, especially once EPD backplane becomes totally flexible

# Emerging Touch Technologies...1

## ❖ Waveguide infrared (“Digital Waveguide Touch”)

- ◆ Only one supplier (RPO), ***and they just went into liquidation***
- ◆ At least one major eReader OEM had committed to use them
  - The OEM (or someone else) may buy the IP & other assets, and the technology may survive
- ◆ Good solution for eReaders
  - Light guide (glass or plastic) underneath the EPD, so no light loss
  - Zero-force touch & multi-touch
  - Very low power consumption
  - Higher resolution → finger or stylus
  - Easily scalable up to 14”
  - Very good ambient light rejection

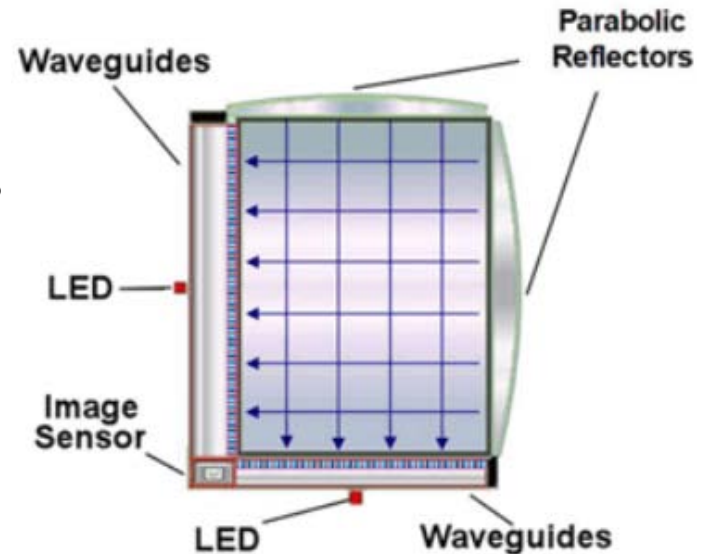

Source: RPO

# Emerging Touch Technologies...2

## ❖ Hanvon's EMR + force-sensing

### ◆ High-resolution stylus plus any-touch

- ◆ Adds an array of piezo-capacitors (used in pen tip to sense pressure) to EMR sensor behind EPD display
  - EMR controller enhanced to support force-sensing → still one chip
  - Nothing added in front of display → no light loss
  - Very light touch (under 10 grams)
  - Palm rejection with auto-switch between pen and finger
  - Multi-touch by end of 2011
  - Fast response (200 pps)
  - Low cost & low power consumption
- ◆ Will be validated in Hanvon-branded products first, then released to market

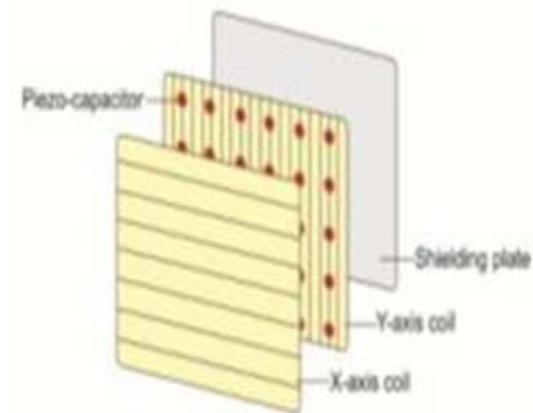

Source: Hanvon

# Potential Touch Technologies...1

---

## ❖ “Traditional” force-sensing



### ◆ FloatingTouch, LLC (early-stage startup)

- Any-touch with nothing added in front of display
- Display mounts on 2-mm flexible adhesive pad that contains sensors
- May support multi-touch & palm rejection (TBD)

### ◆ F-Origin (restructured startup)



- Any-touch with (theoretically) nothing added in front of display
- Advanced mechanical display-suspension system
- Company is focused on traditional single-touch vertical applications
  - Partnered with TPK

# Potential Touch Technologies...2

## ❖ Elo's Acoustic Pulse Recognition (APR) + Sensitive Object's Reversys

- ◆ Any-touch with nothing added in front of display
- ◆ Prototype with piezos integrated into E-ink display
- ◆ Second generation of combined technology is still under development
- ◆ Too early to determine if it meets all the requirements

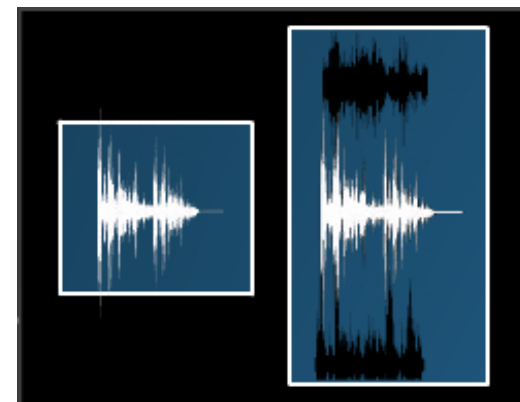
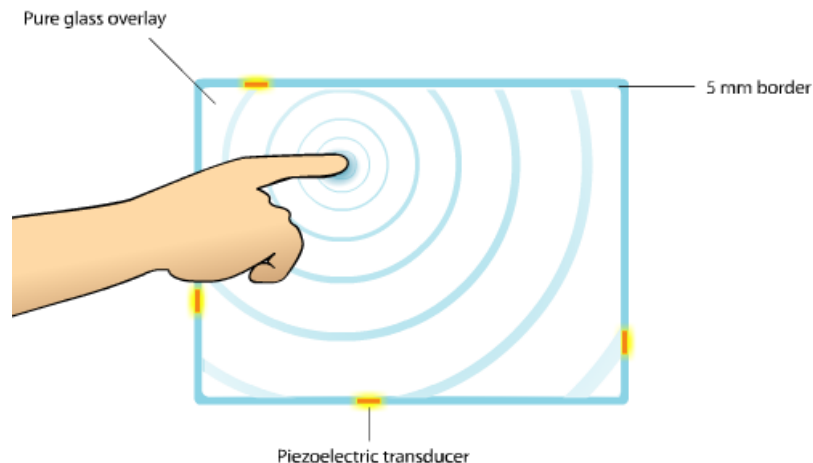

Source: Elo TouchSystems

# Potential Touch Technologies...3

## ❖ Embedded in EPD backplane (“in-cell”)

### ◆ Light-sensing: LGD showed concept at SID 2009

- Visible light → Can't touch black object
- IR light → No reliable source

### ◆ Voltage-sensing: **Not possible**

- Depends on micro-switches between top & bottom of rigid cell

### ◆ Charge-sensing: **Not possible**

- Depends on change in dielectric constant of LC material

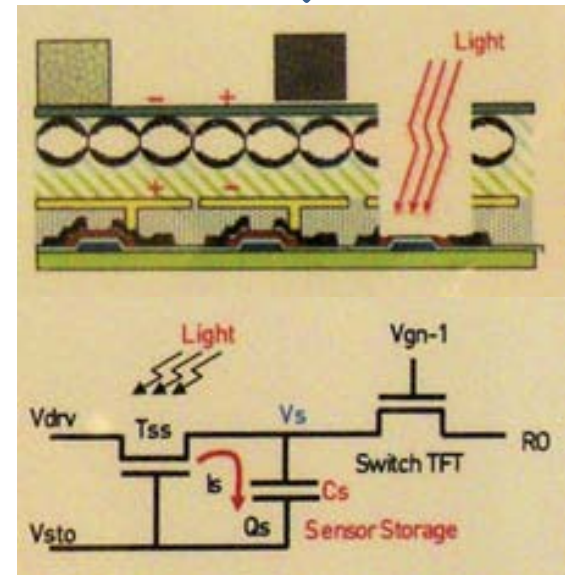

Source: LG Displays

## ❖ Deposited on EPD frontplane (“on-cell”)

### ◆ Charge-sensing: Possible with 2<sup>nd</sup> film layer for protection

- **AUO/SiPix may be doing this**

# Conclusions – Part 2

eReader Touch Technology	Current Usage/Status*	Geoff's Rating	Comment
EMR Pen Digitizer	33%	B	No finger-touch
Capacitive	33%	B	No stylus (yet)
Resistive (on top of EPD)	18%	D	Worst choice (but low-cost)
Traditional Infrared	11%	B	Low resolution & scalability
EMR + Resistive (on top)	<5%	C	Only Samsung (expensive)
Resistive (underneath EPD)	Concept	C	Expensive force-sensing
RPO's Waveguide Infrared	Close	A	Will the technology survive?
Hanvon's EMR + Force-Sensing	Close	A	Needs real-world validation
FloatingTouch's Force-Sensing	Development	B	Potentially very low-cost
F-Origin's Force-Sensing	Vertical Apps	D	Not optimum for eReader
Elo's APR + ReverSys	Development	C	Long development cycle
Embedded in Backplane (in-cell)	Concept	D	No apparent solution
Deposited on Frontplane (on-cell)	AUO/SiPix?	B	Still some light-loss; stylus?

\* Shipment share excluding Kindle; Geoff's estimates



# Thank You!

Geoff Walker

[geoff.walker@imsresearch.com](mailto:geoff.walker@imsresearch.com)

+1 408-945-1221 office

+1 408-506-7556 mobile

**File Download:** [www.walkermobile.com/SID\\_2011\\_Seminar\\_M16.pdf](http://www.walkermobile.com/SID_2011_Seminar_M16.pdf)

**IMS Research Europe**

3-5 Huxley Close,  
Wellingborough,  
Northants,  
NN8 6AB, England

T: +44 1933 402 255  
F: +44 1933 402 266

**IMS Research USA**

3301 Northland Drive,  
Suite 400,  
Austin, TX 78731  
USA

T: +1 512 302 1977  
F: +1 512 302 1844

**IMS Research China**

Room 605, Tower B,  
Orient Intl. Plaza,  
85 Lou Shan Guan Road,  
Shanghai, 200336, PRC

T: +86 21 6270 1823  
F: +86 21 6270 1833

**IMS Research Taiwan**

6F-1, No.8, Lane 18,  
Sec.1, Yunghe Rd  
YungHe City, 234,  
Taipei, Taiwan

T: +886 939 842 065

**IMS Research Korea**

Room 350  
Gangbyeon Metro Center  
Seongjin Bldg. 3F, 593-15  
Guui-3-dong, Gwangjin-gu,  
Seoul, Korea 143-831

T: +82 70 8661 2035  
F: +82 2 6925 3810