

Touch Technologies for eReaders

Geoff Walker
Principal Analyst
IMS Research

August 9, 2011



Agenda

- ❖ **Touch-Usage Requirements [1]**
- ❖ **System-Level Requirements [1]**
- ❖ **Current Touch Technologies [4]**
 - ◆ Electromagnetic resonance pen digitizer (EMR), capacitive, traditional infrared, and resistive
- ❖ **Emerging Touch Technologies [2]**
 - ◆ Waveguide infrared [RPO]
 - ◆ EMR with integrated force-sensing [Hanvon]
- ❖ **Potential Touch Technologies [3]**
 - ◆ Traditional force-sensing, Acoustic Pulse Recognition/ReverSys [Elo], and embedded (“in-cell/on-cell”)
- ❖ **Conclusions [1]**

[Total = 12]

Touch-Usage Requirements

❖ Selection

- ◆ High accuracy

❖ Swipes

- ◆ Very light touch & fast response (iPhone set the standard)

❖ Zoom

- ◆ Multi-touch
 - *Better with images stored at higher resolution than displayed*

❖ Annotation

- ◆ Stylus with palm rejection
 - *Better with software infrastructure for saving annotations with location in text, even when text is reflowed*
- ◆ High-resolution ink for readability
- ◆ Desirable: Handwriting recognition (conversion from ink to text)



System-Level Requirements

❖ Zero light loss (eReader = EPD!)

- ◆ Transmissivity: Light goes through the touch-screen twice!
- ◆ Reflectivity: Reflected light reduces image contrast

❖ Very low power consumption

- ◆ Typical usage model doesn't help

❖ Durable & light weight

- ◆ Very Desirable: No added glass
- ◆ Hard surface for annotations

❖ Insensitive to ambient light

- ◆ Works in bright sunlight with lots of IR



Current Touch Technologies...1

❖ Electromagnetic resonance pen digitizer (EMR)

- ◆ Most common “touch” technology in eReaders
 - Wacom & Hanvon are primary suppliers
- ◆ Sensor goes behind EPD, so no light loss
 - But NO finger touch, and electronic pen is at risk for being lost
- ◆ High resolution ink & inherent palm rejection
- ◆ Lack of infrastructure reduces value of annotation today

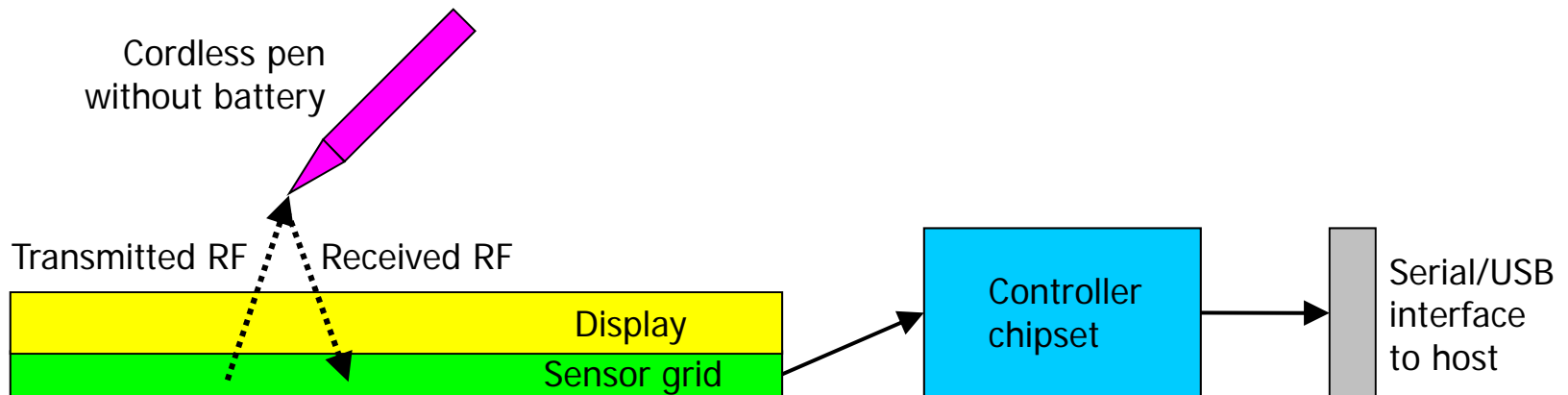

Source: Author

Current Touch Technologies...2

❖ Capacitive

- ◆ Same technology as in iPhone & 100% of tablets
- ◆ Light touch & multi-touch
- ◆ Surface can be flush (“zero-bezel”)
- ◆ Light loss can be minimized to 2-4%
- ◆ Finger-only (so far), so no annotation
 - Palm rejection is achievable when stylus arrives
- ◆ Still very expensive: 7” ≈ \$25 OEM cost with controller (film/film/cover-glass)
- ◆ AUO/SiPix is using laminated film/film/no-glass with a hard-coat cover film

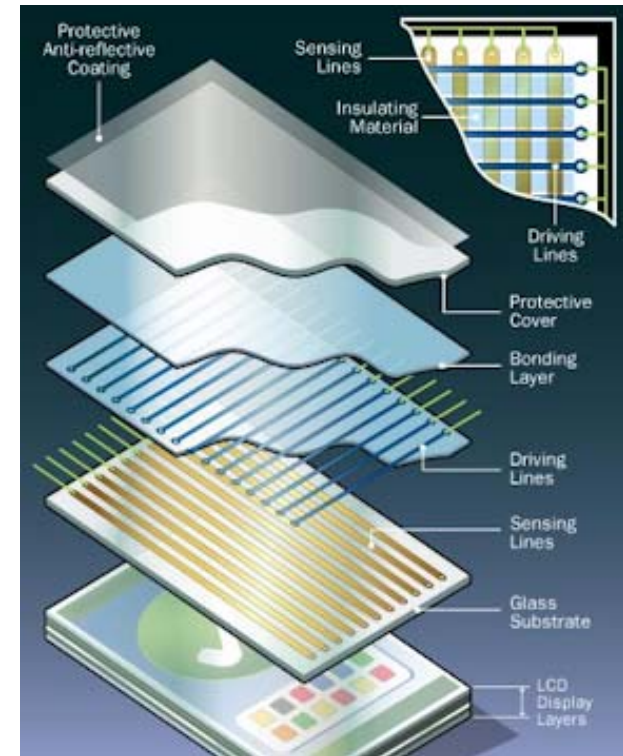

Source: HowStuffWorks.com

Current Touch Technologies...3

❖ Traditional infrared (for mobile)

- ◆ Only one supplier today: Neonode (Sweden)
 - Small company licensing IP, not selling hardware
- ◆ Used in Sony, Koobe, latest Nook, and maybe others
- ◆ No glass, so no light loss
 - IR beams above EPD surface → non-flush bezel
- ◆ Relatively low resolution
- ◆ Doesn't scale very well



Source: Neonode and Pen Computing Magazine



Current Touch Technologies...4

❖ Resistive on top of EPD

- ◆ All single-touch today
 - Nobody has announced the use of multi-touch resistive yet; it seems unlikely because it's not enough of an improvement
- ◆ Least desirable current technology
 - 15% to 20% light loss (glass + 2xITO + PET + air-gap)
 - Reducing surface reflectivity is expensive
 - Requires heavier touch
 - No palm rejection



Source: Sony

❖ Resistive *underneath* EPD

- ◆ Demonstrated by E-ink at SID 2010
- ◆ Potential solution, especially once EPD backplane becomes totally flexible

Emerging Touch Technologies...1

❖ Waveguide infrared (“Digital Waveguide Touch”)

- ◆ Only one supplier (RPO), **and their IP is on the market**
- ◆ At least one major eReader OEM had committed to use them
 - The OEM (or someone else) may buy the IP & other assets, and the technology may survive
- ◆ Good solution for eReaders
 - Light guide (glass or plastic) underneath the EPD, so no light loss
 - Zero-force touch & multi-touch
 - Very low power consumption
 - Higher resolution → finger or stylus
 - Easily scalable up to 14”
 - Very good ambient light rejection

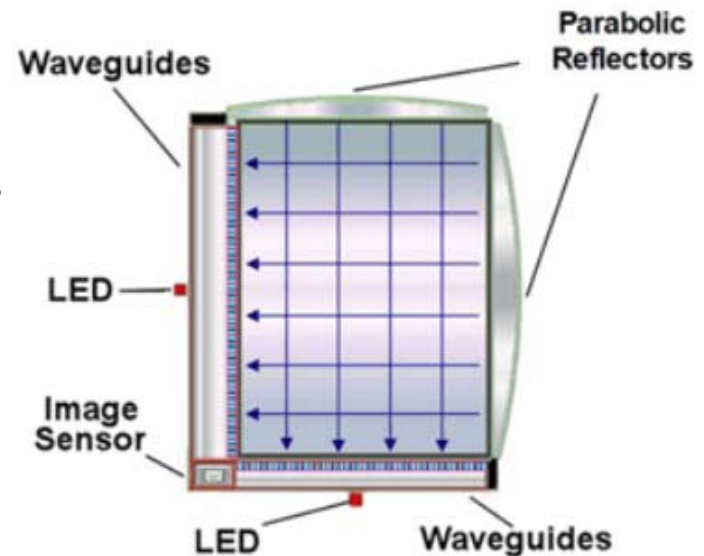

Source: RPO

Emerging Touch Technologies...2

❖ Hanvon's EMR + force-sensing

◆ High-resolution stylus plus any-touch

- ◆ Adds an array of piezo-capacitors (used in pen tip to sense pressure) to EMR sensor behind EPD display
 - EMR controller enhanced to support force-sensing → still one chip
 - Nothing added in front of display → no light loss
 - Very light touch (under 10 grams)
 - Palm rejection with auto-switch between pen and finger
 - Multi-touch planned by end of 2011
 - Fast response (200 pps)
 - Low cost & low power consumption
- ◆ Will be validated in Hanvon-branded products first, then released to market

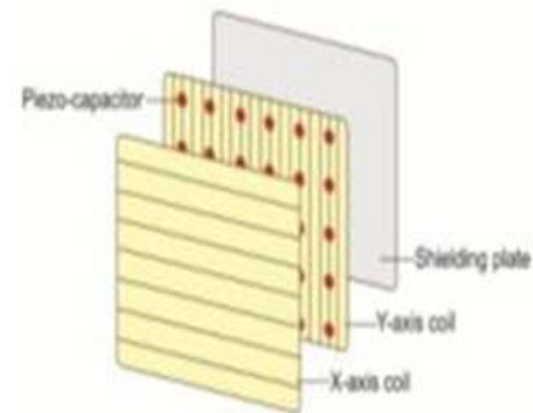

Source: Hanvon

Potential Touch Technologies...1

❖ “Traditional” force-sensing



◆ FloatingTouch, LLC (early-stage startup)

- Any-touch with nothing added in front of display
- Display mounts on 2-mm flexible adhesive pad that contains sensors
- May support multi-touch & palm rejection (TBD)

◆ Impress (spin-off from Pressure Profile Systems)

- Similar concept to FloatingTouch

◆ F-Origin (restructured startup)



- Any-touch with (theoretically) nothing added in front of display
- Advanced mechanical display-suspension system
- Company is focused on traditional single-touch vertical applications
 - Partnered with TPK

Potential Touch Technologies...2

❖ Elo's Acoustic Pulse Recognition (APR) + Sensitive Object's Reversys

- ◆ Any-touch with nothing added in front of display
- ◆ Prototype with piezos integrated into E-ink display
- ◆ Second generation of combined technology is still under development
- ◆ Too early to determine if it meets all the requirements

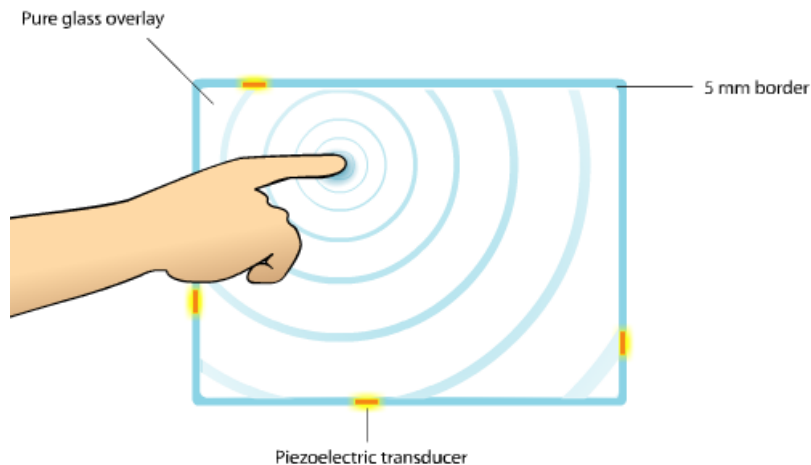

Source: Elo TouchSystems

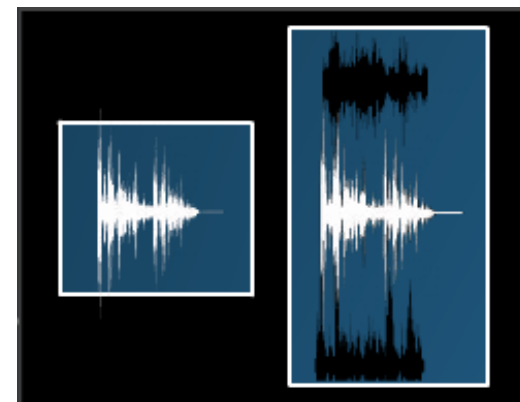

Source: Sensitive Object

Potential Touch Technologies...3

❖ Embedded in EPD backplane (“in-cell”)

◆ Light-sensing: LGD showed concept at SID 2009

- Visible light → Can't touch black object
- IR light → No reliable source

◆ Voltage-sensing: **Not possible**

- Depends on micro-switches between top & bottom of rigid cell

◆ Charge-sensing: **Not possible**

- Depends on change in dielectric constant of LC material

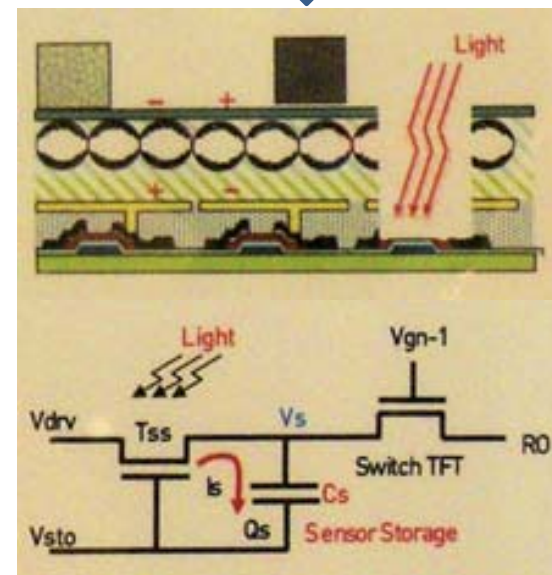

Source: LG Displays

❖ Deposited on EPD frontplane (“on-cell”)

- ◆ Charge-sensing: Possible with 2nd film layer for protection

Conclusions

eReader Touch Technology	Current Usage/Status*	Geoff's Rating	Comment
EMR Pen Digitizer	30%	B	No finger-touch
Capacitive	30%	B	No stylus (yet)
Resistive (on top of EPD)	17%	D	Worst choice (but low-cost)
Traditional Infrared	20%	B	Low resolution & scalability
EMR + Resistive (on top)	3%	C	Only Samsung (expensive)
Resistive (underneath EPD)	Concept	C	Expensive force-sensing
RPO's Waveguide Infrared	Close	A	Will the technology survive?
Hanvon's EMR + Force-Sensing	Close	A	Needs real-world validation
FloatingTouch's Force-Sensing	Development	B	Potentially very low-cost
F-Origin's Force-Sensing	Vertical Apps	D	Not optimum for eReader
Elo's APR + ReverSys	Development	C	Long development cycle
Embedded in Backplane (in-cell)	Concept	D	No apparent solution
Deposited on Frontplane (on-cell)	AUO/SiPix?	B	Still some light-loss; stylus?

* Shipment share of eReaders with touch (author's estimates)



Thank You!

Geoff Walker

geoff.walker@imsresearch.com

+1 408-945-1221 office

+1 408-506-7556 mobile

File Download: www.walkermobile.com/Touch_Technologies_for_eReaders.pdf

IMS Research Europe

3-5 Huxley Close,
Wellingborough,
Northants,
NN8 6AB, England

T: +44 1933 402 255
F: +44 1933 402 266

IMS Research USA

3301 Northland Drive,
Suite 400,
Austin, TX 78731
USA

T: +1 512 302 1977
F: +1 512 302 1844

IMS Research China

Room 605, Tower B,
Orient Intl. Plaza,
85 Lou Shan Guan Road,
Shanghai, 200336, PRC

T: +86 21 6270 1823
F: +86 21 6270 1833

IMS Research Taiwan

6F-1, No.8, Lane 18,
Sec.1, Yunghe Rd
YungHe City, 234,
Taipei, Taiwan

T: +886 939 842 065

IMS Research Korea

Room 350
Gangbyeon Metro Center
Seongjin Bldg. 3F, 593-15
Guui-3-dong, Gwangjin-gu,
Seoul, Korea 143-831

T: +82 70 8661 2035
F: +82 2 6925 3810